

Modified Truss Head Streaker® - Interior

Lath or Light-Gauge Steel-to-Steel Framing

GRABBER
CONSTRUCTION PRODUCTS

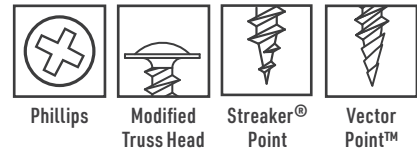
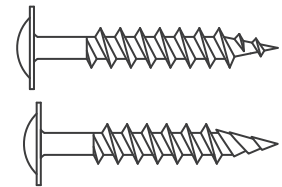
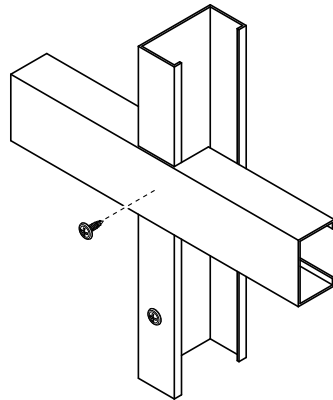
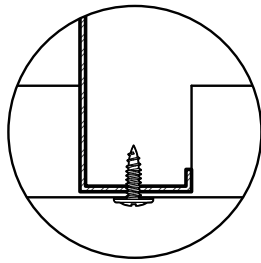

Description Lath or light-gauge steel-to-steel framing.

Specifications

- Size | Gauge:** #7 to #10
- Length:** 9/16 in. to 4 in.
- Head Type:** Modified Truss Head
- Recess Type:** #2 Phillips
- Thread Type:** Fine, Single Lead
- Finish:** Phosphate, Clear Zinc

Quality Assurance: Grabber® fasteners are manufactured in ISO 9001 and ISO 14001 certified and approved factories.

LEED Reporting: The post-consumer recycled steel content is 25%.

Compliance: The fasteners comply with ASTM C1513 and C1002 performance requirements.

Applications

- Light-gauge steel framing
- K-lath installation

- Light-gauge steel-to-steel applications

Installation

- Suggested screw gun specification for optimal performance: sizes #7 to #10, up to 4,000 RPM.
- The Modified Truss head is fully seated when the bearing surface is flush with the work surface.

- The fastener must penetrate beyond the steel three full thread pitches.
- Overdriving may result in failure of the fastener or strip-out.

Features

- Grabber's #2 Phillips is a precision recess designed for better bit engagement resulting in less wobble or strip-out.
- Extra-sharp, single lead 23° Streaker® point is designed to penetrate light-gauge steel quickly and easily.

- The super-sharp Vector Point™ starts and drives up to 40% faster than most other fine thread lath and steel framing screws.
- Certain items have underhead serrations that lock tight in steel-to-steel applications.

Modified Truss Head Streaker® - Interior

Lath or Light-Gauge Steel-to-Steel Framing



Standard Corrosion Test Results

Finish	Test	Standard/Protocol	Results
Phosphate	Salt Spray	ASTM B117	24 hrs., no red rust
Clear Zinc	Salt Spray	ASTM B117	12 hrs., no red rust

Note: Salt Spray Testing (SST) results are not intended to predict corrosion in real-world environments. The ASTM B117 standard for SST is recognized industry-wide as an effective tool for comparing different metals and different metal coatings in a tightly controlled, highly corrosive environment for specific periods of time. For more information about corrosion resistance, see the Grabber Guide to Corrosion Resistance for Fasteners.

Pull-Out Test Data¹

Screw Gauge	TPI ²	Steel Gauge	Design Thickness	Tension	Shear
#7	20	25	0.0188 in.	36 lbs.	63 lbs.
		20	0.0346 in.	67 lbs.	158 lbs.
#8	15	25	0.0188 in.	39 lbs.	66 lbs.
		20	0.0346 in.	72 lbs.	164 lbs.
#10	12-15	25	0.0188 in.	46 lbs.	71 lbs.
		20	0.0346 in.	84 lbs.	177 lbs.

¹Test data values reported are allowable as determined by calculations and industry established test criteria, such as ICC-ES Acceptance Criteria and ASTM test standards. Please contact Grabber for detailed information about testing performed for specific products or if ultimate values are needed.

Sheet Steel Gauges

Gauge No.	Design Thickness	Millimeter Equivalent
25	0.0188 in.	0.4775 mm
20	0.0346 in.	0.8788 mm



Product Dimensions

Screw Gauge	B Head Dia.	Recess	D1 Minor Dia.	D2 Major Dia.	TPI ²
#7	0.447 in.	#2 Phillips	.098 in.	0.151 in.	20
#8	0.447 in.	#2 Phillips	.109 in.	0.164 in.	15
	0.447 in.	#2 Phillips	.109 in.	0.164 in.	20
#10	0.447 in.	#2 Phillips	.130 in.	0.190 in.	12
	0.447 in.	#2 Phillips	.130 in.	0.190 in.	15

²TPI stands for Threads Per Inch. This is a count of the number of threads per inch measured along the length of a fastener.

Modified Truss Head Streaker® - Interior

Lath or Light-Gauge Steel-to-Steel Framing



Ordering Information and Product Options

Item No.	Size	Recess	Head Diameter	TPI	Quantity	Weight	Special Features
Phosphate							
31V	7 x 9/16 in.	#2 Phillips	0.447 in.	20	10,000	40 lb.	Underhead serrations, Vector Point™
32	8 x 1 in.	#2 Phillips	0.447 in.	15	5,000	29 lb.	
3138	8 x 1 1/2 in.	#2 Phillips	0.447 in.	15	3,000	24 lb.	
C31DV	7 x 9/16 in.	#2 Phillips	0.364 in.	20	2,000	5 lb.	Collated, Underhead serrations, Vector Point™
Clear Zinc							
31ZV	7 x 9/16 in.	#2 Phillips	0.447 in.	20	10,000	40 lb.	Underhead serrations, Vector Point™
31Z	8 x 9/16 in.	#2 Phillips	0.447 in.	20	10,000	42 lb.	
31LZ	8 x 3/4 in.	#2 Phillips	0.447 in.	15	8,000	35 lb.	
32Z	8 x 1 in.	#2 Phillips	0.447 in.	15	5,000	29 lb.	
G32Z	8 x 1 in.	#2 Phillips	0.447 in.	15	10,000	58 lb.	
33Z	8 x 1 1/4 in.	#2 Phillips	0.447 in.	15	5,000	34 lb.	
3119Z	8 x 3/4 in.	#2 Phillips	0.447 in.	15	8,000	39 lb.	
3138Z	8 x 1 1/2 in.	#2 Phillips	0.447 in.	15	3,000	24 lb.	
FS3138Z	8 x 1 1/2 in.	#2 Phillips	0.447 in.	15	3,000	25 lb.	
3140Z	8 x 1 5/8 in.	#2 Phillips	0.447 in.	15	3,000	25 lb.	
3145Z	8 x 1 3/4 in.	#2 Phillips	0.447 in.	15	4,000	36 lb.	
3151Z	8 x 2 in.	#2 Phillips	0.447 in.	15	2,500	25 lb.	
3163Z	8 x 2 1/2 in.	#2 Phillips	0.447 in.	15	2,500	29 lb.	
3176Z	8 x 3 in.	#2 Phillips	0.447 in.	15	2,500	15 lb.	
311038Z	10 x 1 1/2 in.	#2 Phillips	0.447 in.	12	4,000	38 lb.	
311019Z	10 x 3/4 in.	#2 Phillips	0.447 in.	12	5,000	24 lb.	
311025Z	10 x 1 in.	#2 Phillips	0.447 in.	12	4,000	25 lb.	
31102Z	10 x 4 in.	#2 Phillips	0.447 in.	12	1,000	25 lb.	
3189Z	10 x 3 1/2 in.	#2 Phillips	0.447 in.	12	1,000	22 lb.	

Note: Product availability is subject to change without prior notice and the availability of products may differ from what is printed in literature and displayed on our website. The items listed are bulk size. Most are also available in smaller package sizes such as 5 lb. and 1 lb. Contact your local Grabber Branch or GrabberPro for more information.

Modified Truss Head Streaker® - Interior
PS1024 USA-ENG/Rev. 02-25

GRABBER CONSTRUCTION PRODUCTS, INC.
5255 W 11000 N., STE 100
HIGHLAND, UT 84003

(800) 477-8876 | GrabberPro.com

SAFETY FIRST: Wear appropriate personal protective equipment. Read applicable SDS and literature before handling and installation.

TECHNICAL INFORMATION: Technical information contained herein is furnished without charge or obligation and is given and accepted at the recipient's sole risk. Because conditions of use may vary and are beyond our control, Grabber Construction Products makes no representation about, and is not responsible or liable for, the accuracy or reliability of data associated with uses of any product described herein. Grabber Construction Products reserves the right to modify this document without prior notice.

© 2025 Grabber Construction Products, Inc. | All rights reserved | Printed in U.S.A.
The trademarks Grabber, Vector Point, Streaker, and Stylized G on Grabber Fasteners, are trademarks of Grabber Construction Products, Inc.

