

Revised Flat Pan Head Driller - Interior

Heavy-Gauge Steel to Heavy-Gauge Steel

GRABBER
CONSTRUCTION PRODUCTS

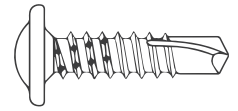
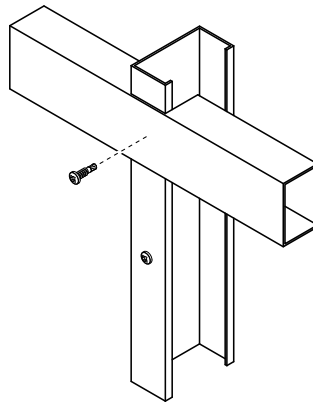
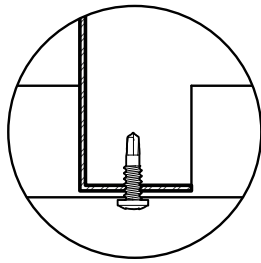

X-Drive



Revised Flat
Pan Head



Drill Point

Description Heavy-gauge steel to heavy-gauge steel connections.

Specifications

Size | Gauge: #10
Length: 3/4 in.
Head Type: Revised Flat Pan Head
Recess Type: X-Drive
Thread Type: Fine, Single Lead
Finish: Clear Zinc Cr3+, Phosphate, Yellow Zinc

Quality Assurance: Grabber® fasteners are manufactured in ISO 9001 and ISO 14001 certified and approved factories.
LEED Reporting: The post-consumer recycled steel content is 25%.
Compliance: The fasteners comply with ASTM C1513 performance requirements.

Applications

- Heavy-gauge steel framing to heavy-gauge steel
- Strapping to heavy-gauge steel
- Fixtures to heavy-gauge steel

Installation

- Use a standard screw gun with a depth-sensitive nose piece. Suggested screw gun specification for optimal performance: size #10, up to 2,500 RPM.
- Because of significantly higher torque output, care and caution should be exercised when using an impact driver; otherwise, screw failure or spin-out may occur.
- The revised flat pan head is fully seated when it is flush with the work surface.
- The fastener must penetrate beyond the steel three full thread pitches.
- Overdriving may result in failure of the fastener.

Features

- Revised flat pan head design provides a larger load-bearing surface for better holding power.
- Underhead serrations lock tight in steel-to-steel applications.
- Self-tapping drill point is designed for penetration into heavy-gauge steel.
- Consistently formed extra-sharp drill point starts and drills easily into heavy-gauge steel.

Revised Flat Pan Head Driller - Interior

Heavy-Gauge Steel to Heavy-Gauge Steel



Standard Corrosion Test Results

Finish	Test	Standard/Protocol	Results
Phosphate	Salt Spray	ASTM B117	24 hrs., no red rust
Yellow Zinc	Salt Spray	ASTM B117	24 hrs., no red rust
Clear Zinc	Salt Spray	ASTM B117	12 hrs., no red rust

Note: Salt Spray Testing (SST) results are not intended to predict corrosion in real-world environments. The ASTM B117 standard for SST is recognized industry-wide as an effective tool for comparing different metals and different metal coatings in a tightly controlled, highly corrosive environment for specific periods of time. For more information about corrosion resistance, see the Grabber Guide to Corrosion Resistance for Fasteners.

Pull-Out Test Data¹

Screw Gauge	TPI ²	Steel Gauge	Design Thickness	Tension	Shear
#10	18	18	0.0451 in.	109 lbs.	263 lbs.
		16	0.0566 in.	198 lbs.	370 lbs.
		14	0.0713 in.	249 lbs.	523 lbs.
		12	0.1017 in.	356 lbs.	891 lbs.
		10	0.1242 in.	434 lbs.	1,199 lbs.

¹Test data values reported are allowable as determined by calculations and industry established test criteria, such as ICC-ES Acceptance Criteria and ASTM test standards. Please contact Grabber for detailed information about testing performed for specific products or if ultimate values are needed.

Sheet Steel Gauges

Gauge No.	Design Thickness	Millimeter Equivalent
25	0.0188 in.	0.4775 mm
20	0.0346 in.	0.8788 mm
18	0.0451 in.	1.1455 mm
16	0.0566 in.	1.4376 mm
14	0.0713 in.	1.8110 mm
12	0.1017 in.	2.5832 mm
10	0.1242 in.	3.1547 mm

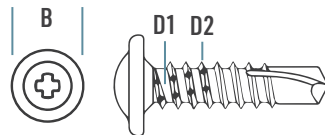

Product Dimensions

Screw Gauge	B Head Dia.	Recess	D1 Minor Dia.	D2 Major Dia.	TPI ²
#10	0.447 in.	X-Drive	0.130 in.	0.190 in.	18

²TPI stands for Threads Per Inch. This is a count of the number of threads per inch measured along the length of a fastener.

Revised Flat Pan Head Driller - Interior Heavy-Gauge Steel to Heavy-Gauge Steel



Ordering Information and Product Options

Item No.	Size	Recess	Head Diameter	TPI	Quantity	Weight	Special Features
Phosphate							
FP101875XD	10 x 3/4 in.	X-Drive	0.344 in.	18	8,000	36 lb.	4 Underhead serrations, Notched upper threads
Yellow Zinc							
FP101875XDYZ	10 x 3/4 in.	X-Drive	0.344 in.	18	8,000	36 lb.	4 Underhead serrations, Notched upper threads
FP101875XDC35	10 x 3/4 in.	X-Drive	0.344 in.	18	8,000	36 lb.	
MCFP101875XDYZ	10 x 3/4 in.	X-Drive	0.344 in.	18	1,000	5 lb.	Collated, 4 Underhead serrations, Notched upper threads
CFP101875XDYZ	10 x 3/4 in.	X-Drive	0.344 in.	18	1,000	5 lb.	Collated, 4 Underhead serrations, Notched upper threads
Clear Zinc Cr3+							
FP101875XDZ	10 x 3/4 in.	X-Drive	0.344 in.	18	8,000	36 lb.	4 Underhead serrations, Notched upper threads

Note: Product availability is subject to change without prior notice and the availability of products may differ from what is printed in literature and displayed on our website. The items listed are bulk size. Most are also available in smaller package sizes such as 5 lb. and 1 lb. Contact your local Grabber Branch or GrabberPro for more information.

Revised Flat Pan Head Driller - Interior
PS1012 USA-ENG/Rev. 02-25

GRABBER CONSTRUCTION PRODUCTS, INC.
5255 W 11000 N., STE 100
HIGHLAND, UT 84003

(800) 477-8876 | GrabberPro.com

SAFETY FIRST: Wear appropriate personal protective equipment. Read applicable SDS and literature before handling and installation.

TECHNICAL INFORMATION: Technical information contained herein is furnished without charge or obligation and is given and accepted at the recipient's sole risk. Because conditions of use may vary and are beyond our control, Grabber Construction Products makes no representation about, and is not responsible or liable for, the accuracy or reliability of data associated with uses of any product described herein. Grabber Construction Products reserves the right to modify this document without prior notice.

© 2025 Grabber Construction Products, Inc. | All rights reserved | Printed in U.S.A.
The trademarks Grabber, and Stylized G on Grabber Fasteners, are trademarks of Grabber Construction Products, Inc.

