

# Pan Head Driller - Interior

## Heavy-Gauge Steel to Heavy-Gauge Steel

**GRABBER®**  
CONSTRUCTION PRODUCTS

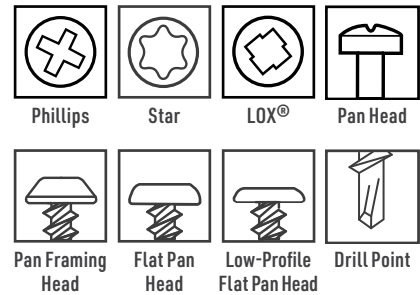
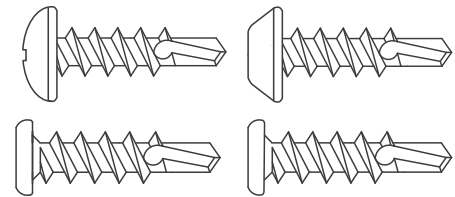
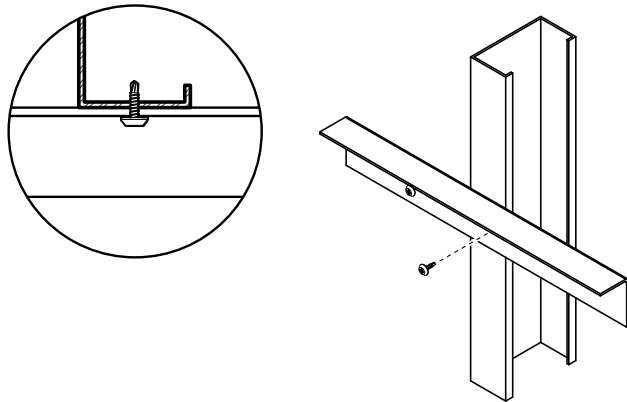

**Description** Heavy-gauge steel to heavy-gauge steel connections, fixtures, backup plates, and door frames.

**Specifications**

**Size | Gauge:** #6 to #12  
**Length:** 1/2 in. to 1 5/8 in.  
**Head Type:** Pan Head, Flat Pan Head, Low-Profile Flat Pan Head, Pan Framing Head  
**Recess Type:** #2 Phillips, T25 Star, #2 LOX®  
**Thread Type:** Fine, Single Lead  
**Finish:** Clear Zinc, Cr3+Zinc, Phosphate, Yellow Zinc

**Quality Assurance:** Grabber® fasteners are manufactured in ISO 9001 and ISO 14001 certified and approved factories.  
**LEED Reporting:** The post-consumer recycled steel content is 25%.  
**Compliance:** The fasteners comply with ASTM C1513 performance requirements. Specific fasteners are listed in ICC ESR-1271; please check the report for listed item numbers.

**Applications**

- Heavy-gauge steel framing to heavy-gauge steel
- Pre-fabrication of heavy-gauge steel trusses
- Strapping to heavy-gauge steel

- Fixtures to heavy-gauge steel
- Steel studs to track
- Steel studs to door frame jamb anchor clips

**Installation**

- Use a standard screw gun with a depth-sensitive nose piece. Suggested screw gun specification for optimal performance: sizes #6 to #10, up to 2,500 RPM, size #12, up to 1,800 RPM.
- Because of significantly higher torque output, care and caution should be exercised when using an impact driver; otherwise, screw failure or spin-out may occur.

- In the pan head family of screws, all are fully seated when the head is flush with the work surface.
- The fastener must penetrate beyond the steel three full thread pitches.
- Overdriving may result in failure of the fastener.

**Features**

- Pan head family of screws provides a flat bearing surface.
- Underhead serrations lock tight in steel-to-steel applications.

- Self-tapping drill point is designed for penetration into heavy-gauge steel.
- Consistently formed extra-sharp drill point starts and drills easily into heavy-gauge steel.

# Pan Head Driller - Interior

## Heavy-Gauge Steel to Heavy-Gauge Steel



### Standard Corrosion Test Results

| Finish      | Test       | Standard/Protocol | Results              |
|-------------|------------|-------------------|----------------------|
| Phosphate   | Salt Spray | ASTM B117         | 24 hrs., no red rust |
| Yellow Zinc | Salt Spray | ASTM B117         | 24 hrs., no red rust |
| Clear Zinc  | Salt Spray | ASTM B117         | 12 hrs., no red rust |
| Cr3+ Zinc   | Salt Spray | ASTM B117         | 24 hrs., no red rust |

Note: Salt Spray Testing (SST) results are not intended to predict corrosion in real-world environments. The ASTM B117 standard for SST is recognized industry-wide as an effective tool for comparing different metals and different metal coatings in a tightly controlled, highly corrosive environment for specific periods of time. For more information about corrosion resistance, see the Grabber Guide to Corrosion Resistance for Fasteners.

### Pull-Out Test Data<sup>1</sup>

| Screw Gauge | TPI <sup>2</sup> | Steel Gauge | Design Thickness | Tension  | Shear      |
|-------------|------------------|-------------|------------------|----------|------------|
| #6          | 20               | 18          | 0.0451 in.       | 79 lbs.  | 224 lbs.   |
|             |                  | 16          | 0.0566 in.       | 144 lbs. | 315 lbs.   |
|             |                  | 14          | 0.0713 in.       | 181 lbs. | 446 lbs.   |
|             |                  | 12          | 0.1017 in.       | 258 lbs. | 759 lbs.   |
|             |                  | 10          | 0.1242 in.       | 315 lbs. | 1,001 lbs. |
| #8          | 18               | 18          | 0.0451 in.       | 94 lbs.  | 244 lbs.   |
|             |                  | 16          | 0.0566 in.       | 171 lbs. | 344 lbs.   |
|             |                  | 14          | 0.0713 in.       | 215 lbs. | 486 lbs.   |
|             |                  | 12          | 0.1017 in.       | 307 lbs. | 827 lbs.   |
|             |                  | 10          | 0.1242 in.       | 375 lbs. | 1,114 lbs. |
| #10         | 16 and 22        | 18          | 0.0451 in.       | 109 lbs. | 263 lbs.   |
|             |                  | 16          | 0.0566 in.       | 198 lbs. | 370 lbs.   |
|             |                  | 14          | 0.0713 in.       | 249 lbs. | 523 lbs.   |
|             |                  | 12          | 0.1017 in.       | 356 lbs. | 891 lbs.   |
|             |                  | 10          | 0.1242 in.       | 434 lbs. | 1,199 lbs. |
| #12         | 18               | 18          | 0.0451 in.       | 124 lbs. | 280 lbs.   |
|             |                  | 16          | 0.0566 in.       | 225 lbs. | 394 lbs.   |
|             |                  | 14          | 0.0713 in.       | 284 lbs. | 557 lbs.   |
|             |                  | 12          | 0.1017 in.       | 405 lbs. | 950 lbs.   |
|             |                  | 10          | 0.1242 in.       | 493 lbs. | 1,278 lbs. |

<sup>1</sup>Test data values reported are allowable as determined by calculations and industry established test criteria, such as ICC-ES Acceptance Criteria and ASTM test standards. Please contact Grabber for detailed information about testing performed for specific products or if ultimate values are needed.

### Sheet Steel Gauges

| Gauge No. | Design Thickness | Millimeter Equivalent |
|-----------|------------------|-----------------------|
| 25        | 0.0188 in.       | 0.4775 mm             |
| 20        | 0.0346 in.       | 0.8788 mm             |
| 18        | 0.0451 in.       | 1.1455 mm             |
| 16        | 0.0566 in.       | 1.4376 mm             |
| 14        | 0.0713 in.       | 1.8110 mm             |
| 12        | 0.1017 in.       | 2.5832 mm             |
| 10        | 0.1242 in.       | 3.1547 mm             |

# Pan Head Driller - Interior

## Heavy-Gauge Steel to Heavy-Gauge Steel

**GRABBER**  
CONSTRUCTION PRODUCTS

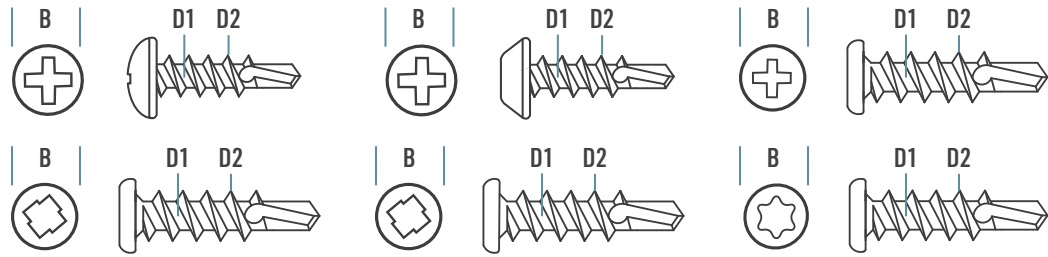

Product  
Dimensions

| Screw Gauge | B Head Dia. | Recess              | D1 Minor Dia. | D2 Major Dia. | TPI <sup>2</sup> |
|-------------|-------------|---------------------|---------------|---------------|------------------|
| #6          | 0.305 in.   | #2 Phillips         | 0.100 in.     | 0.138 in.     | 20               |
| #8          | 0.314 in.   | #2 Phillips         | 0.116 in.     | 0.164 in.     | 18               |
| #10         | 0.313 in.   | #2 Phillips         | 0.132 in.     | 0.190 in.     | 16               |
|             | 0.364 in.   | #2 LOX <sup>®</sup> | 0.135 in.     | 0.190 in.     | 18               |
|             | 0.364 in.   | #2 LOX <sup>®</sup> | 0.135 in.     | 0.190 in.     | 22               |
|             | 0.364 in.   | #2 LOX <sup>®</sup> | 0.137 in.     | 0.190 in.     | 22               |
|             | 0.364 in.   | T20 Star            | 0.137 in.     | 0.190 in.     | 22               |
|             | 0.364 in.   | T25 Star            | 0.137 in.     | 0.190 in.     | 22               |
| #12         | 0.365 in.   | #2 Phillips         | 0.132 in.     | 0.190 in.     | 16               |
|             | 0.364 in.   | #2 LOX <sup>®</sup> | 0.156 in.     | 0.216 in.     | 18               |
|             | 0.364 in.   | T25 Star            | 0.156 in.     | 0.216 in.     | 18               |
|             | 0.364 in.   | #2 LOX <sup>®</sup> | 0.135 in.     | 0.190 in.     | 18               |
|             | 0.364 in.   | #2 LOX <sup>®</sup> | 0.135 in.     | 0.216 in.     | 18               |
|             | 0.364 in.   | #2 LOX <sup>®</sup> | 0.156 in.     | 0.216 in.     | 18               |

<sup>2</sup>TPI stands for Threads Per Inch. This is a count of the number of threads per inch measured along the length of a fastener.

### Ordering Information and Product Options

| Item No.           | Size            | Recess              | Head Diameter | TPI | Quantity | Weight | Special Features                      |
|--------------------|-----------------|---------------------|---------------|-----|----------|--------|---------------------------------------|
| <b>Phosphate</b>   |                 |                     |               |     |          |        |                                       |
| 19                 | 6 x 7/16 in.    | #2 Phillips         | 0.305 in.     | 20  | 15,000   | 41 lb. | Pan Framing Head                      |
| <b>Yellow Zinc</b> |                 |                     |               |     |          |        |                                       |
| FP101875LYZ        | 10 x 3/4 in.    | #2 LOX <sup>®</sup> | 0.364 in.     | 18  | 8,000    | 43 lb. | ICC ESR-1271, Flat Pan Head           |
| FP101875LYZ4M      | 10 x 3/4 in.    | #2 LOX <sup>®</sup> | 0.364 in.     | 18  | 4,000    | 22 lb. |                                       |
| FP101875LYZ3       | 10 x 3/4 in.    | #2 LOX <sup>®</sup> | 0.364 in.     | 18  | 8,000    | 43 lb. | Flat Pan Head                         |
| FP102275LYZ        | 10 x 3/4 in.    | #2 LOX <sup>®</sup> | 0.364 in.     | 22  | 8,000    | 42 lb. | ICC ESR-1271, Flat Pan Head           |
| FP121875LYZ        | 12 x 3/4 in.    | #2 LOX <sup>®</sup> | 0.364 in.     | 18  | 8,000    | 50 lb. |                                       |
| FP121878LYZ        | 12 x 7/8 in.    | #2 LOX <sup>®</sup> | 0.364 in.     | 18  | 6,000    | 44 lb. | Flat Pan Head                         |
| FLP101875LYZ       | 10-18 x 3/4 in. | #2 LOX <sup>®</sup> | 0.364 in.     | 18  | 8,000    | 43 lb. | Low-Profile Flat Pan Head             |
| CFP101875LYZ       | 10 x 3/4 in.    | #2 LOX <sup>®</sup> | 0.364 in.     | 18  | 1,000    | 5 lb.  | Collated, ICC ESR-1271, Flat Pan Head |
| CFP101875LYZ1.5    | 10 x 3/4 in.    | #2 LOX <sup>®</sup> | 0.364 in.     | 18  | 1,500    | 8 lb.  | Collated, Flat Pan Head               |
| CFP101875LYZ3      | 10 x 3/4 in.    | #2 LOX <sup>®</sup> | 0.364 in.     | 18  | 1,000    | 5 lb.  |                                       |

# Pan Head Driller - Interior

## Heavy-Gauge Steel to Heavy-Gauge Steel

# GRABBER®

CONSTRUCTION PRODUCTS

### Ordering Information and Product Options (continued)

| Item No.                       | Size           | Recess      | Head Diameter | TPI | Quantity | Weight | Special Features                      |                             |
|--------------------------------|----------------|-------------|---------------|-----|----------|--------|---------------------------------------|-----------------------------|
| <b>Yellow Zinc (continued)</b> |                |             |               |     |          |        |                                       |                             |
| CFP102275LYZ                   | 10 x 3/4 in.   | #2 LOX®     | 0.364 in.     | 22  | 1,000    | 5 lb.  | Collated, ICC ESR-1271, Flat Pan Head |                             |
| CFP121875LYZ                   | 12 x 3/4 in.   | #2 LOX®     | 0.364 in.     | 18  | 1,000    | 5 lb.  |                                       |                             |
| CFP102275TYZ                   | 10 x 3/4 in.   | T25 Star    | 0.364 in.     | 22  | 1,000    | 5 lb.  | Collated, Flat Pan Head               |                             |
| CFP102275SYZ                   | 10 x 3/4 in.   | #2 LOX®     | 0.364 in.     | 22  | 1,000    | 5 lb.  |                                       |                             |
| CFP121878LYZ                   | 12 x 7/8 in.   | #2 LOX®     | 0.364 in.     | 18  | 1,000    | 5 lb.  |                                       |                             |
| CFP121875LYZ1.5                | 12 x 3/4 in.   | #2 LOX®     | 0.364 in.     | 18  | 1,500    | 8 lb.  |                                       |                             |
| CFP121875TYZ                   | 12 x 3/4 in.   | T25 Star    | 0.364 in.     | 18  | 1,000    | 5 lb.  |                                       |                             |
| CCFP12158LYZ                   | 12 x 1 5/8 in. | #2 LOX®     | 0.364 in.     | 18  | 1,000    | 5 lb.  |                                       |                             |
| <b>Clear Zinc</b>              |                |             |               |     |          |        |                                       |                             |
| 19Z                            | 6 x 7/16 in.   | #2 Phillips | 0.305 in.     | 20  | 15,000   | 41 lb. | Pan Framing Head                      |                             |
| 20Z                            | 8 x 1/2 in.    | #2 Phillips | 0.314 in.     | 18  | 10,000   | 32 lb. | Pan Head                              |                             |
| 10058P3                        | 10 x 5/8 in.   | #2 Phillips | 0.365 in.     | 16  | 7,500    | 39 lb. |                                       |                             |
| 10075P3                        | 10 x 3/4 in.   | #2 Phillips | 0.365 in.     | 16  | 5,000    | 30 lb. |                                       |                             |
| 08075P                         | 8 x 3/4 in.    | #2 Phillips | 0.314 in.     | 18  | 7,500    | 41 lb. |                                       |                             |
| 08100P                         | 8 x 1 in.      | #2 Phillips | 0.314 in.     | 18  | 7,500    | 38 lb. |                                       |                             |
| 08150P                         | 8 x 1 1/2 in.  | #2 Phillips | 0.314 in.     | 18  | 5,000    | 35 lb. |                                       |                             |
| 08200P                         | 8 x 2 in.      | #2 Phillips | 0.314 in.     | 18  | 3,000    | 28 lb. |                                       |                             |
| 10050P                         | 10 x 1/2 in.   | #2 Phillips | 0.365 in.     | 16  | 10,000   | 35 lb. |                                       |                             |
| 10075P                         | 10 x 3/4 in.   | #2 Phillips | 0.365 in.     | 16  | 5,000    | 30 lb. |                                       |                             |
| 10100P                         | 10 x 1 in.     | #2 Phillips | 0.365 in.     | 16  | 5,000    | 35 lb. |                                       |                             |
| 10150P                         | 10 x 1 1/2 in. | #2 Phillips | 0.365 in.     | 16  | 3,000    | 37 lb. |                                       |                             |
| 06075P                         | 6 x 3/4 in.    | #2 Phillips | 0.305 in.     | 20  | 15,000   | 38 lb. |                                       |                             |
| 06100P                         | 6 x 1 in.      | #2 Phillips | 0.305 in.     | 20  | 15,000   | 40 lb. |                                       |                             |
| 08050P                         | 8 x 1/2 in.    | #2 Phillips | 0.314 in.     | 18  | 10,000   | 33 lb. |                                       |                             |
| 10200P                         | 10 x 2 in.     | #2 Phillips | 0.365 in.     | 16  | 2,500    | 37 lb. |                                       |                             |
| 1058FP                         | 10 x 5/8 in.   | #2 Phillips | 0.313 in.     | 16  | 10,000   | 40 lb. |                                       | Flat Pan Head               |
| FP101875JBWZ                   | 10 x 3/4 in.   | #2 LOX®     | 0.364 in.     | 18  | 8,000    | 43 lb. |                                       | ICC ESR-1271, Flat Pan Head |
| FP121878JBWZ                   | 12 x 7/8 in.   | #2 LOX®     | 0.364 in.     | 18  | 6,000    | 44 lb. |                                       |                             |
| FP1218150JBWZ                  | 12 x 1 1/2 in. | #2 LOX®     | 0.364 in.     | 18  | 3,000    | 38 lb. | Flat Pan Head                         |                             |
| CFP101875JBWZ                  | 10 x 3/4 in.   | #2 LOX®     | 0.364 in.     | 16  | 1,000    | 5 lb.  | Collated, ICC ESR-1271, Flat Pan Head |                             |
| CFP101858JBWZ                  | 10 x 5/8 in.   | #2 LOX®     | 0.364 in.     | 18  | 1,000    | 5 lb.  |                                       |                             |
| CFP121878JBWZ                  | 12 x 7/8 in.   | #2 LOX®     | 0.364 in.     | 18  | 1,000    | 5 lb.  | Collated, Flat Pan Head               |                             |
| CFP121875L2Z                   | 12 x 3/4 in.   | #2 LOX®     | 0.364 in.     | 18  | 1,000    | 5 lb.  |                                       |                             |
| CFP121875TZ                    | 12 x 3/4 in.   | T25 Star    | 0.364 in.     | 18  | 1,000    | 5 lb.  |                                       |                             |
| <b>Cr3+ Zinc</b>               |                |             |               |     |          |        |                                       |                             |
| FP101875LCR3                   | 10 x 3/4 in.   | #2 LOX®     | 0.364 in.     | 18  | 8,000    | 43 lb. | Flat Pan Head                         |                             |
| FP121875LCR3                   | 12 x 3/4 in.   | #2 LOX®     | 0.364 in.     | 18  | 6,000    | 50 lb. |                                       |                             |
| FP121878LCR3                   | 12 x 7/8 in.   | #2 LOX®     | 0.364 in.     | 18  | 6,000    | 44 lb. |                                       |                             |
| CFP101875LZ38                  | 10 x 3/4 in.   | #2 LOX®     | 0.364 in.     | 18  | 1,000    | 5 lb.  | Collated, Flat Pan Head               |                             |
| CFP101875LCR38                 | 10 x 3/4 in.   | #2 LOX®     | 0.364 in.     | 18  | 1,000    | 5 lb.  |                                       |                             |

Note: Product availability is subject to change without prior notice and the availability of products may differ from what is printed in literature and displayed on our website. The items listed are bulk size. Most are also available in smaller package sizes such as 5 lb. and 1 lb. Contact your local Grabber Branch or GrabberPro for more information.

Pan Head Driller - Interior  
PS1010 USA-ENG/Rev. 02-25

GRABBER CONSTRUCTION PRODUCTS, INC.  
5255 W 11000 N., STE 100  
HIGHLAND, UT 84003

(800) 477-8876 | GrabberPro.com

**SAFETY FIRST:** Wear appropriate personal protective equipment. Read applicable SDS and literature before handling and installation.

**TECHNICAL INFORMATION:** Technical information contained herein is furnished without charge or obligation and is given and accepted at the recipient's sole risk. Because conditions of use may vary and are beyond our control, Grabber Construction Products makes no representation about, and is not responsible or liable for, the accuracy or reliability of data associated with uses of any product described herein. Grabber Construction Products reserves the right to modify this document without prior notice.

© 2025 Grabber Construction Products, Inc. | All rights reserved | Printed in U.S.A.  
The trademarks Grabber, LOX, and Stylized G on Grabber Fasteners, are trademarks of Grabber Construction Products, Inc.

