

# Hex Head Driller - Interior

## Heavy-Gauge Steel-to-Steel

**GRABBER®**  
CONSTRUCTION PRODUCTS

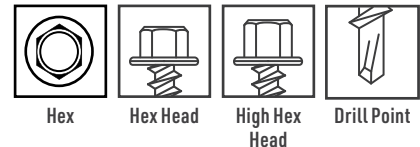
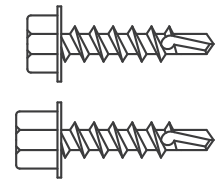
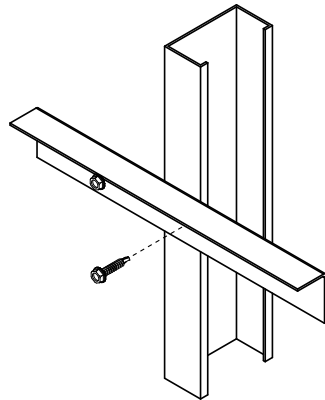
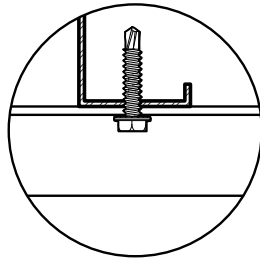

**Description** Attaches fixtures, backup plates, door frames, and lathers channel to structural studs and other heavy-gauge steel.

**Specifications**

**Size | Gauge:** #8 to #14  
**Length:** 1/2 in. to 6 in.  
**Head Type:** Hex Head, High Hex Head  
**Recess Type:** n/a  
**Thread Type:** Fine, Single Lead  
**Finish:** Clear Zinc, Yellow Zinc

**Quality Assurance:** Grabber® fasteners are manufactured in ISO 9001 and ISO 14001 certified and approved factories.  
**LEED Reporting:** The post-consumer recycled steel content is 25%.  
**Compliance:** The fasteners comply with ASTM C1513 performance requirements. Specific fasteners are listed in ICC ESR-1271; please check the report for listed item numbers.

**Applications**

- Steel studs to track, 20-12-gauge steel (33-97 mil)
- Steel studs to door frame jamb anchor clips
- Plaster grounds to 20-8 gauge steel
- Other steel-to-steel attachments, 20-12 gauge (33-97 mil)

**Installation**

- Use a standard screw gun with a depth-sensitive nose piece. Suggested screw gun specification for optimal performance: sizes #8 and #10, up to 2,500 RPM, sizes #12 and #14, up to 1,800 RPM.
- Because of significantly higher torque output, care and caution should be exercised when using an impact driver; otherwise, screw failure or spin-out may occur.
- The hex head is fully seated when the bearing surface of the head is flush with the work surface.
- The fastener must penetrate beyond the steel three full thread pitches.
- Overdriving may result in failure of the fastener.

**Features**

- Self-tapping drill point is designed for penetration into heavy-gauge steel.
- Hex head provides maximum driving torque with a flat bearing surface.
- Hex washer head design provides for a larger load-bearing surface for better holding power.
- Consistently formed extra-sharp drill point starts and drills easily into heavy-gauge steel framing.
- Also available with #3, #4, and #5 drill point.

# Hex Head Driller - Interior

## Heavy-Gauge Steel-to-Steel



### Standard Corrosion Test Results

Finish	Test	Standard/Protocol	Results
Clear Zinc	Salt Spray	ASTM B117	12 hrs., no red rust
Yellow Zinc	Salt Spray	ASTM B117	24 hrs., no red rust

Note: Salt Spray Testing (SST) results are not intended to predict corrosion in real-world environments. The ASTM B117 standard for SST is recognized industry-wide as an effective tool for comparing different metals and different metal coatings in a tightly controlled, highly corrosive environment for specific periods of time. For more information about corrosion resistance, see the Grabber Guide to Corrosion Resistance for Fasteners.

### Pull-Out Test Data<sup>1</sup>

Screw Gauge	TPI <sup>2</sup>	Steel Gauge	Design Thickness	Tension	Shear
#8	18	18	0.0451 in.	94 lbs.	244 lbs.
		16	0.0566 in.	171 lbs.	344 lbs.
		14	0.0713 in.	215 lbs.	486 lbs.
		12	0.1017 in.	307 lbs.	827 lbs.
		10	0.1242 in.	375 lbs.	1,114 lbs.
#10	16 and 22	18	0.0451 in.	109 lbs.	263 lbs.
		16	0.0566 in.	198 lbs.	370 lbs.
		14	0.0713 in.	249 lbs.	523 lbs.
		12	0.1017 in.	356 lbs.	891 lbs.
		10	0.1242 in.	434 lbs.	1,199 lbs.
#12	14 and 24	18	0.0451 in.	124 lbs.	280 lbs.
		16	0.0566 in.	225 lbs.	394 lbs.
		14	0.0713 in.	284 lbs.	557 lbs.
		12	0.1017 in.	405 lbs.	950 lbs.
		10	0.1242 in.	493 lbs.	1,278 lbs.
#14	14 and 20	18	0.0451 in.	139 lbs.	297 lbs.
		16	0.0566 in.	252 lbs.	417 lbs.
		14	0.0713 in.	318 lbs.	590 lbs.
		12	0.1017 in.	453 lbs.	1,005 lbs.
		10	0.1242 in.	553 lbs.	1,353 lbs.

<sup>1</sup>Test data values reported are allowable as determined by calculations and industry established test criteria, such as ICC-ES Acceptance Criteria and ASTM test standards. Please contact Grabber for detailed information about testing performed for specific products or if ultimate values are needed.

### Sheet Steel Gauges

Gauge No.	Design Thickness	Millimeter Equivalent
25	0.0188 in.	0.4775 mm
20	0.0346 in.	0.8788 mm
18	0.0451 in.	1.1455 mm
16	0.0566 in.	1.4376 mm
14	0.0713 in.	1.8110 mm
12	0.1017 in.	2.5832 mm
10	0.1242 in.	3.1547 mm

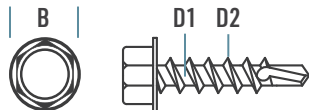

### Product Dimensions

Screw Gauge	B Head Dia.	Drive Size	D1 Minor Dia.	D2 Major Dia.	TPI <sup>2</sup>
#8	0.335 in.	1/4 in.	0.116 in.	0.164 in.	18
	0.399 in.	5/16 in.	0.138 in.	0.190 in.	16
#10	0.415 in.	5/16 in.	0.138 in.	0.190 in.	14
	0.335 in.	5/16 in.	0.161 in.	0.216 in.	14
#12	0.415 in.	5/16 in.	0.161 in.	0.216 in.	14
	0.415 in.	5/16 in.	0.161 in.	0.216 in.	24
#14	0.500 in.	3/8 in.	0.183 in.	0.242 in.	14

<sup>2</sup>TPI stands for Threads Per Inch. This is a count of the number of threads per inch measured along the length of a fastener.

# Hex Head Driller - Interior

## Heavy-Gauge Steel-to-Steel

**GRABBER**  
CONSTRUCTION PRODUCTS

Heavy-Gauge Steel

Heavy-Gauge Steel-to-Steel

### Ordering Information and Product Options

Item No.	Size	Drive Type	Head Diameter	TPI	Quantity	Weight	Special Features
Clear Zinc							
08050H	8 x 1/2 in.	1/4 in. Hex	0.335 in.	18	15,000	33 lb.	
10050H	10 x 1/2 in.	5/16 in. Hex	0.399 in.	16	7,500	37 lb.	
10075HA	10 x 3/4 in.	5/16 in. Hex	0.399 in.	16	5,000	30 lb.	
12075HA	12 x 3/4 in.	5/16 in. Hex	0.335 in.	14	5,000	39 lb.	
14300H	14 x 3 in.	3/8 in. Hex	0.500 in.	14	1,000	33 lb.	
08050H3	8 x 1/2 in.	1/4 in. Hex	0.335 in.	18	10,000	34 lb.	
08058H3	8 x 5/8 in.	1/4 in. Hex	0.335 in.	18	10,000	39 lb.	
08075H3	8 x 3/4 in.	1/4 in. Hex	0.335 in.	18	10,000	43 lb.	ICC ESR-1271
08100H3	8 x 1 in.	1/4 in. Hex	0.335 in.	18	7,500	38 lb.	
08100HA	8 x 1 in.	1/4 in. Hex	0.335 in.	18	7,500	38 lb.	
08125H3	8 x 1 1/4 in.	1/4 in. Hex	0.335 in.	18	5,000	31 lb.	
08200H3	8 x 2 in.	1/4 in. Hex	0.335 in.	18	3,000	28 lb.	ICC ESR-1271
10050H3	10 x 1/2 in.	5/16 in. Hex	0.399 in.	16	7,500	37 lb.	ICC ESR-1271, Hydrogen embrittlement failure protection
10058H3	10 x 5/8 in.	5/16 in. Hex	0.399 in.	16	7,500	42 lb.	
10075H3	10 x 3/4 in.	5/16 in. Hex	0.399 in.	16	5,000	31 lb.	
10100H3	10 x 1 in.	5/16 in. Hex	0.399 in.	16	5,000	38 lb.	ICC ESR-1271, Hydrogen embrittlement failure protection, Underhead serrations
10125H3	10 x 1 1/4 in.	5/16 in. Hex	0.399 in.	16	3,500	31 lb.	
10150H3	10 x 1 1/2 in.	5/16 in. Hex	0.399 in.	16	3,500	36 lb.	
10200H3	10 x 2 in.	5/16 in. Hex	0.399 in.	16	3,000	39 lb.	
10300H3	10 x 3 in.	5/16 in. Hex	0.399 in.	16	1,000	27 lb.	
12075H3	12 x 3/4 in.	5/16 in. Hex	0.415 in.	14	5,000	39 lb.	
12100H3	12 x 1 in.	5/16 in. Hex	0.415 in.	14	3,500	33 lb.	
12125H3	12 x 1 1/4 in.	5/16 in. Hex	0.415 in.	14	3,500	39 lb.	
12150H3	12 x 1 1/2 in.	5/16 in. Hex	0.415 in.	14	2,500	32 lb.	
12134H3	12 x 1 3/4 in.	5/16 in. Hex	0.415 in.	14	2,500	34 lb.	ICC ESR-1271, Hydrogen embrittlement failure protection
12200H3	12 x 2 in.	5/16 in. Hex	0.415 in.	14	2,000	33 lb.	
1224125H4	12 x 1 1/4 in.	5/16 in. Hex	0.415 in.	24	3,000	34 lb.	
1224125H5	12 x 1 1/4 in.	5/16 in. Hex	0.415 in.	24	3,000	33 lb.	
1224200H4	12 x 2 in.	5/16 in. Hex	0.415 in.	24	3,000	35 lb.	
1224200H5SL	12 x 2 in.	5/16 in. Hex	0.415 in.	24	2,000	34 lb.	ICC ESR-1271, Hydrogen embrittlement failure protection, Slotted shank
122478H4	12 x 7/8 in.	5/16 in. Hex	0.415 in.	24	4,000	34 lb.	
12250H3	12 x 2 1/2 in.	5/16 in. Hex	0.415 in.	14	2,000	39 lb.	
12300H3	12 x 3 in.	5/16 in. Hex	0.415 in.	14	1,000	24 lb.	
12350H3	12 x 3 1/2 in.	5/16 in. Hex	0.415 in.	14	1,000	27 lb.	
14075H3	14 x 3/4 in.	3/8 in. Hex	0.500 in.	14	5,000	59 lb.	
14100H3	14 x 1 in.	3/8 in. Hex	0.500 in.	14	3,500	49 lb.	
14125H3	14 x 1 1/4 in.	3/8 in. Hex	0.500 in.	14	2,000	33 lb.	ICC ESR-1271, Hydrogen embrittlement failure protection
14150H3	14 x 1 1/2 in.	3/8 in. Hex	0.500 in.	14	2,000	38 lb.	
14200H3	14 x 2 in.	3/8 in. Hex	0.500 in.	14	1,500	35 lb.	
14250H3	14 x 2 1/2 in.	3/8 in. Hex	0.500 in.	14	1,000	28 lb.	
14300H3	14 x 3 in.	3/8 in. Hex	0.500 in.	14	1,000	33 lb.	
14400H4	14 x 4 in.	3/8 in. Hex	0.500 in.	14	1,000	21 lb.	
14500H4	14 x 5 in.	3/8 in. Hex	0.500 in.	14	500	18 lb.	
14600H5	14 x 6 in.	3/8 in. Hex	0.500 in.	14	500	20 lb.	

# Hex Head Driller - Interior

## Heavy-Gauge Steel-to-Steel

**GRABBER**  
CONSTRUCTION PRODUCTS

### Ordering Information and Product Options (continued)

Item No.	Size	Drive Type	Head Diameter	TPI	Quantity	Weight	Special Features
<b>Clear Zinc (continued)</b>							
08075H3 1M	8 x 3/4 in.	1/4 in. Hex	0.335 in.	18	1,000	5 lb.	
10075HW3CS	10 x 3/4 in.	5/16 in. Hex	0.399 in.	16	5,000	33 lb.	Hydrogen embrittlement failure protection, EPDM washer
12075HBS	12 x 3/4 in.	5/16 in. Hex	0.415 in.	14	5,000	39 lb.	ICC ESR-1271, Hydrogen embrittlement failure protection
1224150H5SL	12-24 x 1 1/2 in.	5/16 in. Hex	0.415 in.	24	2,500	32 lb.	ICC ESR-1271, Hydrogen embrittlement failure protection, Slotted shank
H08050H3	8 x 1/2 in.	1/4 in. Hex	0.335 in.	18	10,000	34 lb.	High Hex Head, ICC ESR-1271
H08058H3	8 x 5/8 in.	1/4 in. Hex	0.335 in.	18	10,000	40 lb.	
H08075H3	8 x 3/4 in.	1/4 in. Hex	0.335 in.	18	10,000	44 lb.	
H08100H3	8 x 1 in.	1/4 in. Hex	0.335 in.	18	7,500	41 lb.	
H08150H3	8 x 1 1/2 in.	1/4 in. Hex	0.335 in.	18	5,000	35 lb.	
H10050H3	10 x 1/2 in.	5/16 in. Hex	0.399 in.	16	7,500	34 lb.	
H10075H3	10 x 3/4 in.	5/16 in. Hex	0.399 in.	16	5,000	30 lb.	High Hex Head, ICC ESR-1271, Hydrogen embrittlement failure protection
H10100H3	10 x 1 in.	5/16 in. Hex	0.399 in.	16	5,000	37 lb.	
H10125H3	10 x 1 1/4 in.	5/16 in. Hex	0.399 in.	16	3,500	33 lb.	
H10150H3	10 x 1 1/2 in.	5/16 in. Hex	0.399 in.	16	3,500	35 lb.	
H10200H3	10 x 2 in.	5/16 in. Hex	0.399 in.	16	3,000	31 lb.	
H12075H3	12 x 3/4 in.	5/16 in. Hex	0.415 in.	14	5,000	40 lb.	
H12100H3	12 x 1 in.	5/16 in. Hex	0.415 in.	14	3,500	40 lb.	
H12125H3	12 x 1 1/4 in.	5/16 in. Hex	0.415 in.	14	3,500	34 lb.	
H12150H3	12 x 1 1/2 in.	5/16 in. Hex	0.415 in.	14	2,500	35 lb.	
H12200H3	12 x 2 in.	5/16 in. Hex	0.415 in.	14	2,000	32 lb.	
H1224125H4	12-24 x 1 1/4 in.	5/16 in. Hex	0.415 in.	24	3,000	35 lb.	High Hex Head, ICC ESR-1271, Hydrogen embrittlement failure protection
H1224200H4	12-24 x 2 in.	5/16 in. Hex	0.415 in.	24	2,000	50 lb.	
H12250H3	12 x 2 1/2 in.	5/16 in. Hex	0.415 in.	14	2,000	30 lb.	
H12300H3	12 x 3 in.	5/16 in. Hex	0.415 in.	14	1,000	22 lb.	
H10078H4	10 x 7/8 in.	5/16 in. Hex	0.415 in.	14	5,000	37 lb.	
H10125H4	10 x 1 1/4 in.	5/16 in. Hex	0.415 in.	14	3,500	33 lb.	
H1224150H4	12-24 x 1 1/2 in.	5/16 in. Hex	0.415 in.	24	2,500	33 lb.	
H122478H4	12-24 x 7/8 in.	5/16 in. Hex	0.415 in.	24	4,000	34 lb.	
<b>Yellow Zinc</b>							
10075H35	10 x 3/4 in.	5/16 in. Hex	0.399 in.	16	5,000	31 lb.	
122278H35YZ	12 22 x 7/8 in.	5/16 in. Hex	0.415 in.	22	4,000	33 lb.	

Note: Product availability is subject to change without prior notice and the availability of products may differ from what is printed in literature and displayed on our website. The items listed are bulk size. Most are also available in smaller package sizes such as 5 lb. and 1 lb. Contact your local Grabber Branch or GrabberPro for more information.

Hex Head Driller - Interior  
PS1008 USA-ENG/Rev. 02-25

GRABBER CONSTRUCTION PRODUCTS, INC.  
5255 W 11000 N., STE 100  
HIGHLAND, UT 84003

(800) 477-8876 | GrabberPro.com

**SAFETY FIRST:** Wear appropriate personal protective equipment. Read applicable SDS and literature before handling and installation.

**TECHNICAL INFORMATION:** Technical information contained herein is furnished without charge or obligation and is given and accepted at the recipient's sole risk. Because conditions of use may vary and are beyond our control, Grabber Construction Products makes no representation about, and is not responsible or liable for, the accuracy or reliability of data associated with uses of any product described herein. Grabber Construction Products reserves the right to modify this document without prior notice.

© 2025 Grabber Construction Products, Inc. | All rights reserved | Printed in U.S.A.  
The trademarks Grabber, and Stylized G on Grabber Fasteners, are trademarks of Grabber Construction Products, Inc.

